

# User Manual

## HINAESS PowerStack



**50A**

Continuous Current

**10**

Year Warranty

**912**

kWh Stackable

## Content

<b>Statement of Law</b> .....	<b>1</b>
<b>Safety handling of lithium batteries Guide</b> .....	<b>2</b>
<b>1 Introduction</b> .....	<b>4</b>
1.1 Brief Introduction .....	4
1.3 Product identity definition.....	5
<b>2 Product Specification</b> .....	<b>6</b>
2.1 System Performance Parameter .....	6
2.3 HV CONTROL BOX .....	9
<b>3 Installation and Configuration</b> .....	<b>12</b>
3.1 Environmental Requirement .....	12
3.2 Installation space requirements.....	12
3.3 Installation location precautions .....	13
3.4 Tools.....	13
3.5 Safety Gear.....	13
3.6 Unpacking inspection .....	14
HV CONTROL BOX packing list:Table 3-2 .....	14
Battery Module packing list:Table 3-3 .....	15
3.7 Equipment installation .....	15
<b>4 Maintenance</b> .....	<b>22</b>
4.1 Trouble Shooting:.....	22
4.2 Replacement of main component.....	22
4.3 Battery Maintenance .....	22
<b>5 Storage Recommendations</b> .....	<b>23</b>
<b>6 Shipment</b> .....	<b>23</b>

---

# Statement of Law

---

Copyright of this document belongs to HINAESS TECH CO.,LTD.

No part of this documentation maybe excerpted, reproduced,translated,annotated or duplicated in any form or by any means without the prior written permission of HINAESS TECH CO.,LTD.  
All Rights Reserved.

This product complies with the design requirements of environmental protection and personal safety. The storage, use and disposal of the products shall be carried out in accordance with the product manual, relevant contract or relevant laws and regulations.

Customer can check the related information on the website of HINAESS TECH CO.,LTD when the product or technology is updated.

Web URL: [www.hinaess.com](http://www.hinaess.com)

Please note that the product can be modified without prior notice.

## Revision History

Revision NO.	Revision Date	Revision Reason
1.0	2024.8.7	First Published
1.1	2025.6.17	Update Max.module number in series to be 9

---

## Safety handling of lithium batteries Guide

---



- Battery strings will have high voltage DC power to cause a risk of danger voltage and electric shock.
- Only qualified person can do modules install and connect cables of the battery system.
- DO NOT rotate and unplug the cables while the system is running.



- Warning: This product is a high voltage DC system, operated by authorized person only.



- Caution: Before installing and operating, you must read User Manual carefully

### Before Connecting

- Please check product and packing list first after unpacking, if product is damaged or short of parts, please contact with your local supplier;
- Before installing, make sure the battery is in off mode;
- Do not reverse the positive and negative cables ,and confirm there is no short circuit connection to the external device;
- It is prohibited to connect the battery to AC power directly;
- Battery system must be well grounded ;
- Please make sure the electrical parameters of battery system are compatible to related equipment;
- Keep the battery away from water and fire.

### In Using

- If the battery system needs to be moved or repaired, the power must be cut off and ensure the battery is completely shut down;
- It is prohibited to connect the battery with different types of battery.
- It is prohibited to put the batteries working with faulty or incompatible inverter;
- It is prohibited to disassemble the battery (Warranty tab removed or damaged);
- In case of fire, only dry powder fire extinguisher can be used, liquid fire extinguishers are prohibited;
- Please do not open, repair or disassemble the battery except for staffs from HINAESS or authorized by HINAESS. We do not undertake any consequences or related responsibility which is due to violation of safety operation or equipment safety standards.



**Caution**

- Please read the user manual carefully (in the box of control box );
- If the battery is stored for a long time , it is required to charge them every six months under professional guidance, and the SOC should be no less than 50%;
- Battery needs to be recharged in time when fully discharge;
- Battery need to be 100% full charged regularly,at least once time every 7days,to calibrate SOC;
- All cables connection must be tough and good contact;
- All the battery terminals must be disconnected when need maintain;
- Please contact the supplier within 24 hours if there is something abnormal.
- The warranty claims are excluded for direct or indirect damage due to items above.

# 1 Introduction

---

## 1.1 Brief Introduction

PowerStack is a high voltage battery energy storage system based on LFP cells. Customers can choose up to 9 modules in series to be one cluster to use, and also parallel many clusters to create a larger capacity battery system according to your needs. This product is especially suitable for energy storage applications with high operating temperatures, limited installation space, long power backup time and long service life.

## 1.2 Product Properties

- Comply with European certificate, employ non-toxic, non-pollution environment-friendly battery.
- Positive material is lithium iron phosphate (LiFePO<sub>4</sub>), safer with longer life span.
- Carries battery management system with better performance, has protection function like over-discharge, over-charge, over-current, abnormal temperature.
- Self-management on charging and discharging, balancing function.
- Flexible remote upgrade and remote monitor.
- Flexible configurations allow parallel of multi clusters for longer standby time.
- Self-ventilation with lower system noise.
- Short circuit and reverse connection protection.
- Less battery self-discharge, then recharging period can be up to 12 months during the storage.
- No memory effect so that battery can be charged and discharged shallowly.
- The working environment temperature range is wide, -20 °C ~ +55 °C, and the cycle performance is good at high temperature.
- Support 0.7C charge and discharge
- Support AC wake power, to save battery energy for system self consumption
- Support module numbers adaptive and multi-cluster parallel address adaptive

### 1.3 Product identity definition





Figure 1-1 System nameplate

	<input type="checkbox"/> <input type="checkbox"/> <input type="checkbox"/> <input type="checkbox"/> <input type="checkbox"/> <input type="checkbox"/> <input type="checkbox"/> <input type="checkbox"/>
	2M 3M 4M 5M 6M 7M 8M 9M
Rated Energy(kWh):	10.1 / 15.2 / 20.2 / 25.3 / 30.4 / 35.4 / 40.5 / 45.6
Rated Voltage (V):	140.8 / 211.2 / 281.6 / 352.0 / 422.4 / 492.8 / 563.2 / 633.6
Rated Capacity(Ah):	72 / 72 / 72 / 72 / 72 / 72 / 72 / 72
Charge and Discharge Current(A):	50 / 50 / 50 / 50 / 50 / 50 / 50 / 50
Discharge Work Temp(°C):	_____ -20~55 _____
Charge Work Temp(°C):	_____ 0~50 _____
IP Grade:	_____ 65 _____
Date of manufacture:	
SN:	



	<b>Battery voltage is higher than safe voltage, direct contact with electric shock hazard.</b>
	<b>Caution fire.</b>
	<b>Flammable and Explosive.</b>
	<b>The scrapped battery cannot be put into the garbage can and must be professionally recycled</b>
	<b>Read the user manual before using.</b>
	<b>If catch fire, do not put out with water.</b>
	<b>Do not place near open flame or incinerate.</b>
	<b>Keep away from children.</b>
	<b>After the battery life is terminated, the battery can continue to be used after it recycled by the professional recycling organization and do not discard it at will.</b>
	<b>This battery product meets European directive requirements.</b>

Figure 1-2 Battery module nameplate

	
Model:	PowerStack
Name:	LFP Li-ion Battery
Rated Voltage /Capacity:	70.4V/72Ah
System Energy:	5.06kWh
Max.Charge Voltage:	78.1V
Recommend Cut off Voltage:	66V
Max.Charge Current:	50A
Max.Discharge Current:	50A
Date of manufacture:	
Series Number:	
  	
HINAESS TECH CO.,LTD	

## 2 Product Specification

### 2.1 System Performance Parameter

Table 2-1 The parameter of PowerStack system

System List	2M	3M	4M	5M	6M	7M	8M	9M
Battery Module Quantity(pcs)	2	3	4	5	6	7	8	9
Rated Energy [kWh]	10.12	15.18	20.24	25.30	30.36	35.42	40.48	45.54
DOD	95%							
Module configuration	2 Series	3 Series	4 Series	5 Series	6 Series	7 Series	8 Series	9 Series
Work Voltage Range[Vdc]	127.6~160.6	191.4~240.9	255.2~321.2	319~401.5	382.8~481.8	446.6~562.1	510.4~642.4	574.2~722.7
Rated Voltage (Vdc)	140.8	211.2	281.6	352	422.4	492.8	563.2	633.6
Rated Capacity (Ah)	72							
Charge Voltage (Vdc)	156.2	234.3	312.4	390.5	468.6	546.7	624.8	702.9
Max. continuous Charge current [A]	50.4							
Max. continuous Discharge current [A]	50.4							
Discharge Temp	-20℃~55℃							
Charge Temp	0℃~50℃							
Max. Discharge Power Rated [kW]	7.09	10.64	14.19	17.74	21.28	24.83	28.38	31.93
Enclosure Protection (IP)	IP65							
Size [mm]	736*382*503.5	736*382*640.5	736*382*777.5	736*382*914.5	736*382*1051.5	736*382*1188.5	736*382*1325.5	736*382*1462.5
Weight [kg]	92	138	184	230	276	322	368	414
Communicate type	CAN							

## 6 modules PowerStack system



### 2.2 Battery Module



Table 2-2 Product parameters

PowerStack Module	
Cell Technology	Li-ion(LFP)
Battery Module Capacity (kWh)	5.06
Battery Module Voltage (Vdc)	70.4
Battery Module Capacity (Ah)	72
Battery Module Cell Quantity in Series (pcs)	22
Battery Cell Voltage (Vdc)	3.2
Battery Cell Capacity (Ah)	72
Battery Module Charge Current (Max.) [A]	50.4
Battery Module Charge Voltage (Vdc)	78.1
Battery Module Cut Off Voltage (Vdc)	63.8
Battery Module Discharge Current (Max.) [A]	50.4
Dimension(W*D*H, mm)	736*382*184
Communication mode	CAN
Ambient Temperature(°C)	25
IP Grade	IP65
Weight(kg)	46

Module top interface

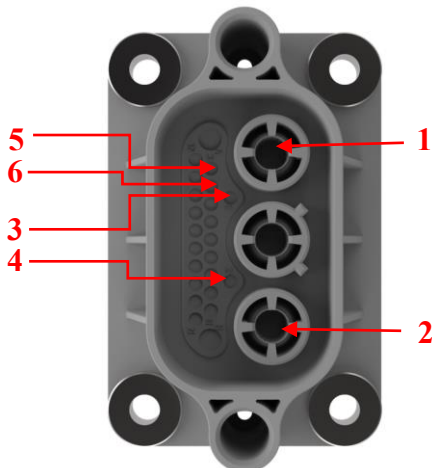

No	Module Top Terminal
1	Negative
2	Positive
3	24V+
4	24V-
5	BMU CANH
6	BMU CANL

Table 2-3 Interface Definition

Module bottom interface

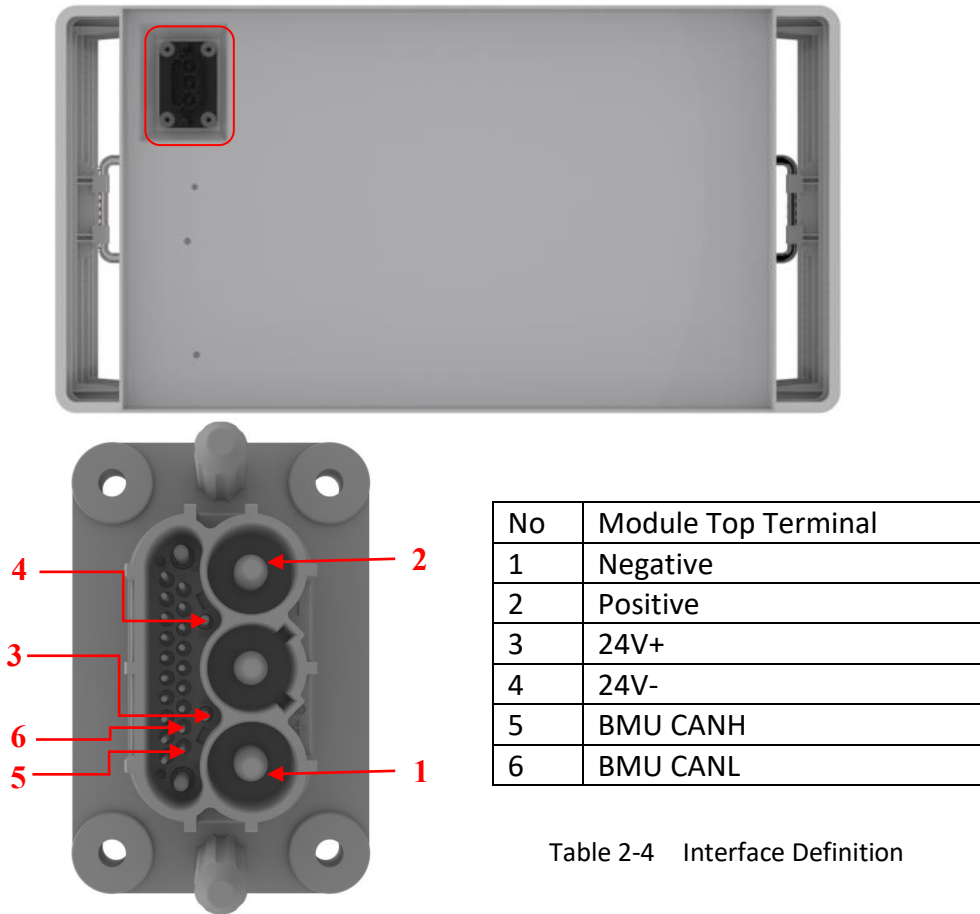
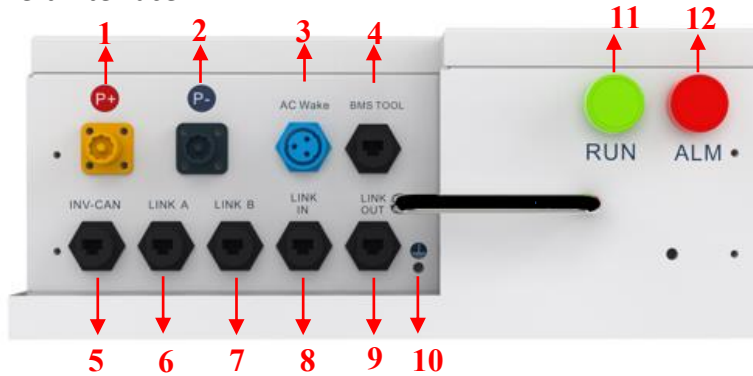

Table 2-4 Interface Definition

**2.3 HV CONTROL BOX**

HV BOX left interface



HV BOX right interface



Item	Name	Definition
1	Positive Output	Battery system positive output terminal
2	Negative Output	Battery system negative output terminal
3	AC Wake	Use a 220V AC power to turn on system,can work with DC Wake at the same time,AC will be priority to supply power
4	BMS TOOL	Connect USB-CAN analysis card to read battery info on laptop
5	INV-CAN	The port for battery communicate to inverter
6	LINK A	When parallel clusters,connect to next HV control box LINK B
7	LINK B	When parallel clusters,connect to next HV control box LINK A
8	LINK IN	When parallel clusters,connect to last HV control box LINK OUT
9	LINK OUT	When parallel clusters,connect to next HV control box LINK IN
10	GROUND	Grounding point
11	RUN	It will be green on or flash when system runs normally
12	ALM	It will be red on or flash when system is alarm
13	DC Wake	Switch on the system,power is from battery module
14	POWER	Turn on to make battery system output power

Table 2-5 Interface Definition

## HV BOX bottom interface

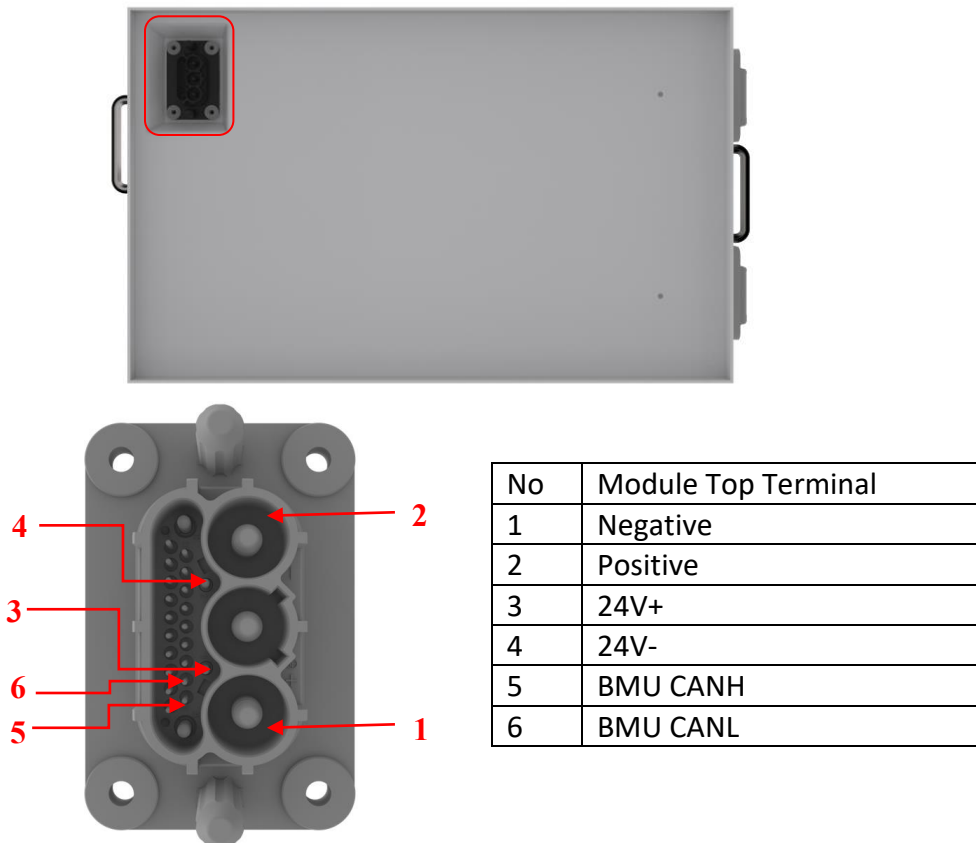



**Caution:** When the DC breaker trip off because of over current or short circuit or low voltage or high temperature or some protects else, you can't turn on it again until find out the exact reason.



**Caution:** Ensure the Power Switch is turned on firstly before waking up the battery, Otherwise it will affect the parallel auto addressing and system internal check.



**Power Switch:** Generally when it is at ON state, you can't turn off it during charge and discharge.



**Danger:** DO NOT turn off any of switches on HV Control Box during normal charge and discharge state, only in emergency situation it could be turned off directly.

Definition of “INV-CAN” port pin

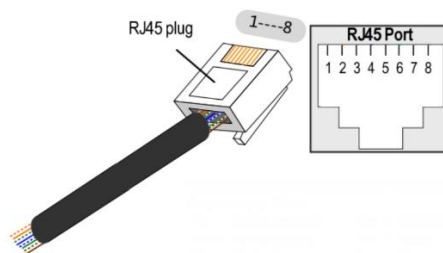

PIN	Color	Definition
PIN1	Orange/White	NC
PIN2	Orange	NC
PIN3	Green/White	NC
PIN4	Blue	CANH
PIN5	Blue/White	CANL
PIN6	Green	NC
PIN7	Brown/White	NC
PIN8	Brown	NC

## 3 Installation and Configuration

### 3.1 Environmental Requirement

#### 3.1.1 Cleanliness

It will be better to keep a clean environment before installing system. Dust and humidity condition shall be regularly checked during the system continuous running.

#### 3.1.2 Temperature

PowerStack system working temperature range: 0°C~55°C; Optimum temperature: 25°C;

**Caution:** Out of the working temperature range will cause the battery system over / low temperature alarm or protection and also make effect on the battery's cycle life.

#### 3.1.3 Cooling System

It is better to equip a cooling system to keep the battery system work in a relevant temperature range.

#### 3.1.4 Heating System

It is better to equip a heating system to keep the battery system work in a relevant temperature range. If the cells temp is lower than 0°C, the system will not allow to be charged.

#### 3.1.5 Fire Extinguishing System

The site must be equipped with Fire Extinguishing system for safety purpose. The Fire Extinguishing system needs to be regularly checked to make sure it is normal .

#### 3.1.6 Grounding System

Make sure the grounding point for battery system is stable and reliable before installing.

### 3.2 Installation space requirements

Please note that the battery should be installed with a minimum distance from the surrounding equipment or battery. Please refer to the minimum clearance diagram below.



### 3.3 Installation location precautions

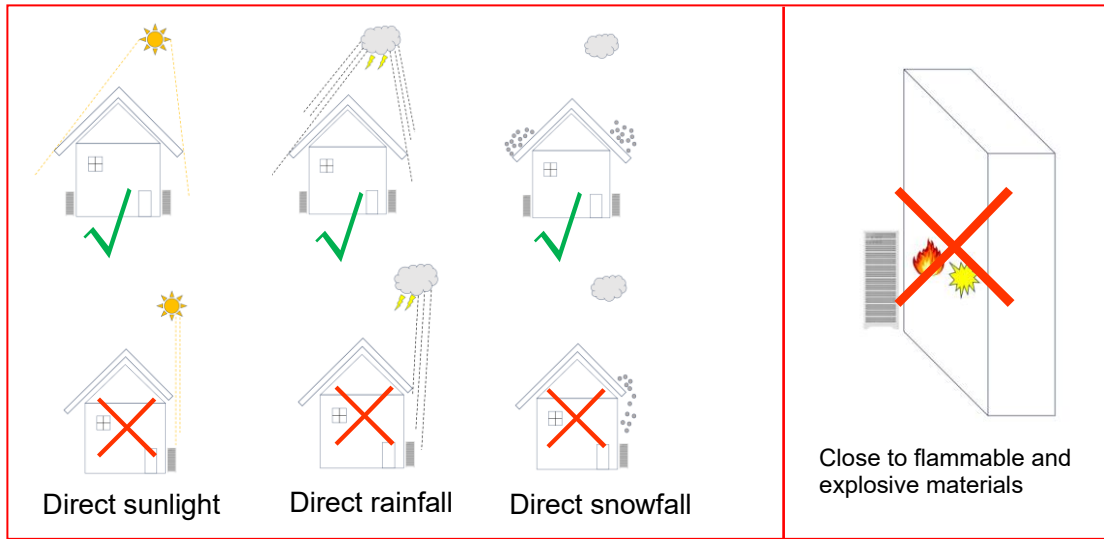

### 3.4 Tools

The following tools are required to install the battery pack: Table 3-1

wire stripping pliers	Diagonal pliers	Cable crimper with crystal head
Phillips screwdriver	Torque wrench set	multimeter
Laptop	USB-CAN analysis card	CAT5 net work cable

**NOTE:**

Use properly insulated tools to prevent accidental electric shock or short circuits. If insulated tools are not available, cover the entire exposed metal surfaces with available insulated alternatives, except their tip, with electrical tape.

### 3.5 Safety Gear

It is recommended to wear the following safety gear when dealing with the battery pack



Insulated gloves



Safety goggles







Safety shoes



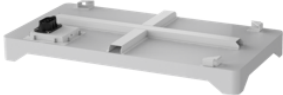

### 3.6 Unpacking inspection

- When the equipment arrives at the installation site, loading and unloading should be carefully operated, to prevent from falling down.
- Battery should not be installed in direct sunlight and rainfall and snowfall. Please refer to Section 3.3
- Before unpacking, the total number of packages shall be indicated according to the shipping list attached to each package, and the case shall be checked for good condition.
- In the process of unpacking, handle with care and protect the surface of the case.
- Open the package, the installer should read the user manual, verify the list, according to the configuration table and packing list, ensure objects are complete and intact, if the internal packing is damaged, should be examined and recorded in detail.



#### Packing list

HV CONTROL BOX packing list:Table 3-2

Item	Specification	Quantity	Figure
HV CONTROL BOX	736*382*159.5mm	1 PCS	
Base	736*382*115.7mm	1 PCS	
Communication cable	Standard,Black /L2000mm /RJ45 plug at both sides	3 PCS	
RJ45 Waterproof connector	Male end	6 PCS	
CAN terminal	CAN terminal resistor,120 Ω	2 PCS	
AC Wake Connector	Waterproof connector,male end	1PCS	
RJ45 crystal head	Spare for comm cable making	4PCS	
M6 screws	M6*16,3 sets of combined screw	2 PCS	

Ground wire	L140mm,4mm <sup>2</sup>	1 PCS	
User Manual	/	1 PCS	
Warranty card	/	1PCS	
Power cable	Positive cable 16mm <sup>2</sup> ,red,2m	1 PCS	
Power cable	Negative cable 16mm <sup>2</sup> ,black,2m	1PCS	

Battery Module packing list:Table 3-3

Item	Specification	Quantity	Figure
M6 screws	M6*16,3 sets of combined screw	1 PCS	
Ground wire	L140mm,4mm <sup>2</sup>	1 PCS	
Battery Module	70.4V/72Ah 736*382*184mm	1 PCS	

### 3.7 Equipment installation

Table 3-4 Installation steps

<b>Step1</b>	Installation preparation	1. The environment should be as requirements: “3.1.1~3.1.6”
<b>Step 2</b>	Module Installation	1. Confirm the placement
		2. Place the base
		2. Stack up battery modules one by one 3. Measure the modules' output voltage on the top module terminal
		4. Stack HV CONTROL BOX

<p><b>Step3</b></p>	<p>Cable Connection</p>	<ol style="list-style-type: none"> <li>1. Connect grounding cable Between CONTROL BOX and module and Base</li> <li>2. Connect standard comm cable from LINK OUT to next COTROL BOX 's LINK IN when parallel system</li> <li>3. Plug standard CAN terminal to the master COTROL BOX 's LINK IN and the last slave's LINK OUT port when parallel system</li> <li>4. Connect standard comm cable from the master LINK B to next LINK A,it will be better to loop a comm cable from the last LINK B back to the master LINK A</li> </ol>
<p><b>Step4</b></p>	<p>Battery system self-check</p>	<ol style="list-style-type: none"> <li>1. Switch on all the POWER breaker of HV BOXes</li> <li>2. Switch on the DC Wake breaker one by one</li> <li>3. Wait for about 1~3 minutes,system will do internal check automatically when parallel system</li> <li>4. Check the system output voltage after all lights of battery are green on</li> <li>5. Switch off DC Wake breakers one by one</li> </ol>
<p><b>Step5</b></p>	<p>Connect to Inverter</p>	<ol style="list-style-type: none"> <li>1. Connect Power Cable to the inverter</li> <li>2. Connect the communication cable from the master INV-CAN to the master inverter CAN</li> </ol>

### 3.7.1 Installation preparation

1. Make sure the environment meets the conditions.
2. Prepare equipments and tools for installation.
3. Confirm that the DC breaker is in the OFF state

### 3.7.2 Modules installation

#### 3.7.2.1 Place the base

- Open the box to take out HV BOX and Base , **accessories package is under the Base.**

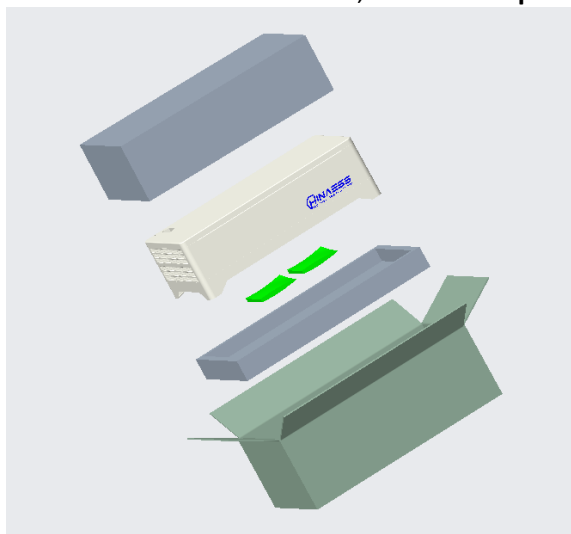

- Move the top cover and two sides of plastic cover, lift the HV BOX and separate it from the BASE. The side trim cover is a snap design that can be pulled outward and removed.



- Place the base in the predetermined position.

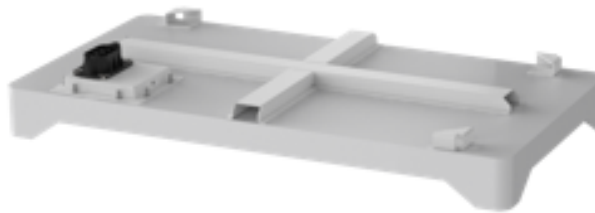

- Open the module box to take out module, remove two sides of trim cover, and then remove the terminal cover from the top and bottom of modules' terminals.



- Stack up modules on base one by one.



- Measure the voltage on the top module positive and negative poles.

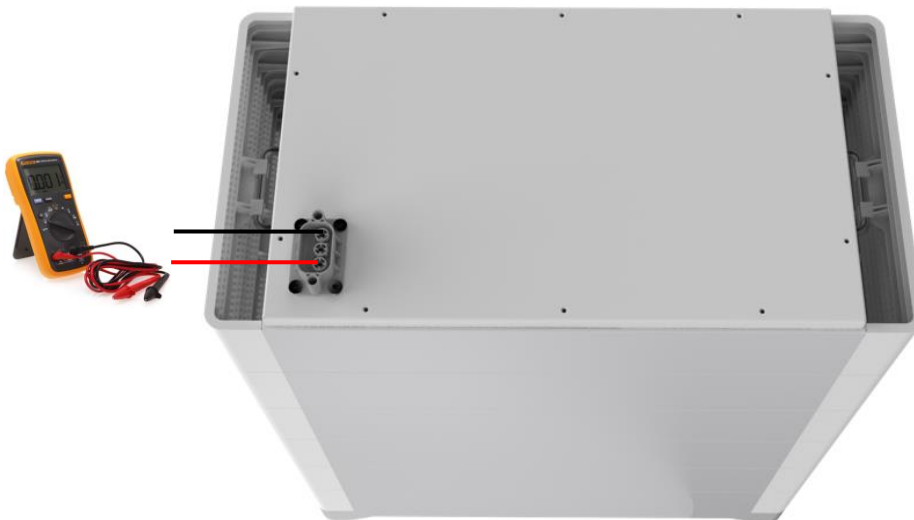

- Stack the HV CONTROL BOX



### 3.7.2.2 Cables connection

- Connect grounding cable Between CONTROL BOX and module and Base



- Connect standard comm cable from LINK OUT to next CONTROL BOX 's LINK IN ,
- Plug CAN terminal resistor to the master CONTROL BOX 's LINK IN and the last slave's LINK OUT port ,when parallel system
- Connect standard comm cable from the master LINK B to next LINK A,it will be better to loop a comm cable from the last LINK B back to the master LINK A

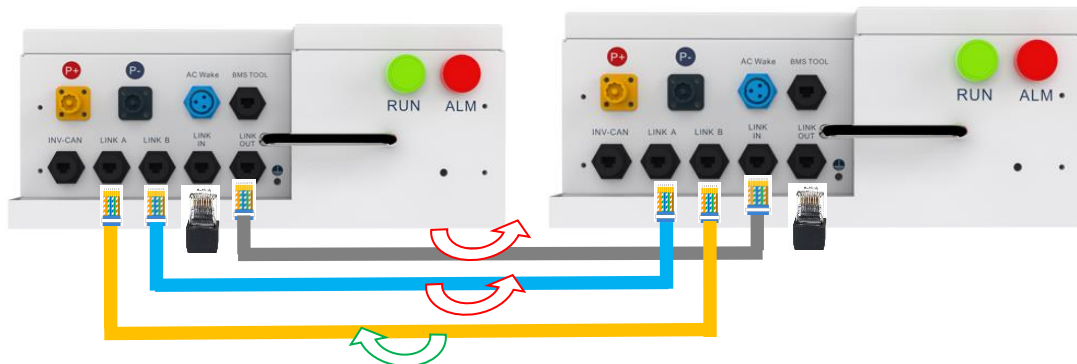

**Warning:** Single battery module is 46kg. It's necessary to arrange more than 1 person to install battery module if without lifting equipment,also when install battery module in higher position.

### 3.7.3 System self-check

#### 3.7.3.1 Switch on all the POWER breaker of HV BOXes

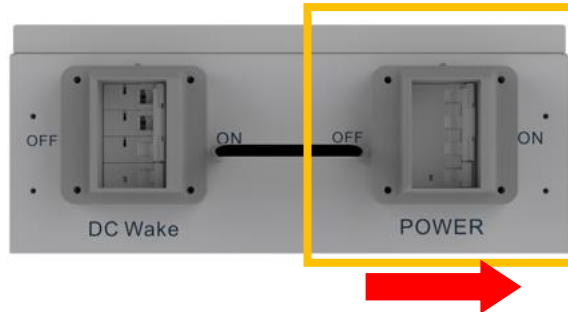

#### 3.7.3.2 Switch on the DC Wake breaker one by one

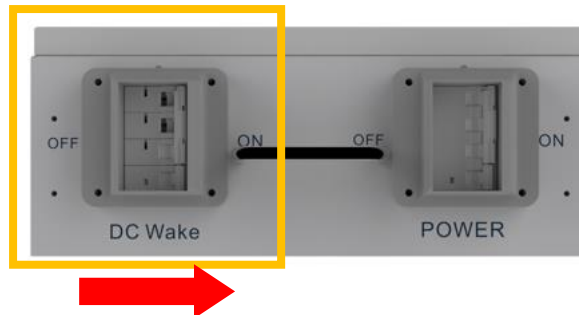

#### 3.7.3.3 Check the system output voltage after all lights of battery are green on.



#### 3.7.3.4 Use a multimeter to measure the output voltage on the positive and negative ports

#### 3.7.3.5 The output voltage should conform to the voltage range in the table Table 2-1.



**Danger:** The voltage of the battery is too high, please pay attention to do self-protection during the measurement.

### 3.7.4 Shut down the system.

Make sure the system is in standby state before shutting down

- Switch off the DC Wake breaker one by one

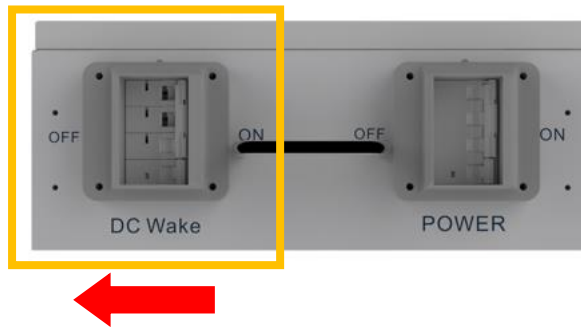

- Switch off the POWER breaker one by one

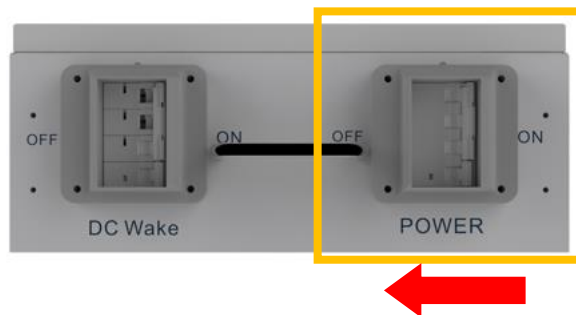

### 3.7.5 Connecting inverter

**Caution: A external DC Breaker between the battery and inverter is recommended. After switching on the battery and see all the RUN lights are green on, you can turn on this external breaker.**

**Danger:**

Please confirm that the battery system is in the off state before connecting. It maybe cause electric shock to personnel and damage to the inverter if connect the battery directly without power off.

- Connect the positive and negative power cables
- Connect Standard comm cable from INV-CAN to the inverter CAN;



**Warning:**

1. Double check all the power cables and communication cable connection is right and good contact.
2. Make sure the battery work voltage is in the inverter work voltage range.
3. Start the battery system. Referring to the section “3.7.3” .
4. Switch on the inverter to check communication is normal or not.

## 4 Maintenance

### 4.1 Trouble Shooting:

**Danger:** The PowerStack battery system is a high voltage DC system, operated by professional and authorized person only.

**Danger:** Before check the failure, must check all the cables connection. Switches are right or not (refer to section 3.7.4), and if the battery system can be woken up normally .

No	Problem	Possible Reason	Solution
1	The battery has no voltage output, but the RUN light is on.	The POWER breaker of the HV BOX is not ON	Switch on the POWER breaker
2		If it is more than 2 clusters parallel system,the internal balance is not yet done	Wait some minutes
3		The fuse in the HV box is faulty	Replace fuse
6	The battery ALM light is on or flash	The relay in HV BOX is faulty/ low SOC alarm /low voltage protect/slaves comm lost/over current,etc.	Check case by case
7	The DC breaker trips automatically	Ove voltage protect/over temp/long time standby 72hours	Check case by case
8	Communication failure between battery and inverter	The wrong battery brand is selected on the inverter/Comm cable bad contact	Select correct battery brand protocol on the inverter/check comm cable connection state

### 4.2 Replacement of main component

**Danger:** The Tower battery system is a high voltage DC system, only can be operated by professional and authorized person.

#### 4.2.1 Replace HV CONTROL BOX

4.2.1.1 Turn off the whole battery system. The shut down progress refer to section 3.5.5

4.2.1.2 Remove the old one and stack new one on module

### 4.3 Battery Maintenance

**Danger:** The maintenance of battery only can be operated by professional and authorized person.

**Danger:** you need turn off the battery system firstly when you do maintenance.

#### 4.3.1 Voltage Inspection:

**[Periodical Maintenance]** Check the voltage of battery system through the monitor software. Check whether the system voltage is normal or not. For example: Check Single cell's voltage is out of rated range or not.

#### 4.3.2 Voltage Inspection:

**[Periodical Maintenance]** Check the SOC of battery system through the monitor software. Check the SOC of battery cluster is normal or not. You need do full charge regularly to calibrate SOC.

#### 4.3.3 Cables Inspection:

**[Periodical Maintenance]** Visual inspect all the cables of battery system. Check the cables have broken, aging, getting loose or not.

## 5 Storage Recommendations

- For long-term storage (more than 3 months), the battery cells should be stored in the environment: temperature range of 10~35°C, relative humidity <65% and contains non-corrosive gas .
- The battery module should be stored in dry, clean and well ventilated environment. The battery should be around 50% SOC before storage.
- It is recommended to active the battery system (discharge and charge) every 3 months, and the longest duration of storage without charge and discharge cannot exceed 6 months.

## 6 Shipment

Battery module will be pre-charged to 50% SOC or according to customer requirement before shipment. The remaining capacity of battery cell is determined by the storage time and condition after shipment.

- The battery modules meet the UN38.3 certificate standard.
- In particular, special rules for the carriage of goods on the road and the current dangerous goods law, specifically ADR(European Convention on the International Carriage of Dangerous Goods by Road), as amended, must be observed.

